

CONTAINS:

INTRODUCTION

1.0 INPUT REQUIREMENTS

1.1 Voltage (VAC)

1.2 Frequency

1.3 In-Rush Current

1.4 Ac Input Current

2.0 OUTPUT REQUIREMENTS

2.1 Output Power

2.2 Output Regulation

2.2.1 Input Voltage

2.2.2 Input Frequency

2.2.3 Static Load

2.2.4 Output Voltage

2.2.5 Ripple

2.3 Transient Response and Deviation

2.4 Turn on, Hold up Time

2.5 Efficiency

3.0 PROTECTION

3.1 Input Current

3.2 Over Voltage Protection

3.3 Over Current Protection

3.4 Short Circuit Protection

4.0 MECHANICAL

4.1 Introduction

4.2 General Requirements

4.3 Power Supply Dimensions

4.4 Input / Output Connection

4.5 Unit Color

5.0 RELIABILITY AND QUALITY CONTROL

5.1 MTBF

5.2 Burn-In

6.0 ENVIRONMENTAL CONDITIONS

6.1 Non-operating

6.1.1 Ambient Temperature

6.1.2 Relative Humidity

6.2 Operating

6.2.1 Ambient Temperature

6.2.2 Relative Humidity

7.0EMI EMISSIONS

8.0SAFETY

8.1 Dielectric Strength (Hi-Pot) Test

8.2 Insulation Resistance

8.3 Leakage current

9.0ENVIRONMENTAL PROTECTION

9.1 RoHS and WEEE

10.0 PACKAGING

11.0 OUTLOOKING

12.0 SAFETY CERTIFICATES

INTRODUCTION

This documents specifies TWO voltage +12V,+5V power supply for electronic data processing equipment. The power supply will provide power to all system components.

1.0 INPUT REQUIREMENTS

1.1 Input Voltage Designing Range: 90~264 VAC.

1.2 Line Frequency Designing Range: 47 HZ to 63 HZ.

1.3 In-Rush Current: 30 A max. less under 115V conditions.

Interruption of the input voltage for duration sufficient to cause the output voltage to drop below the regulation setting shall cause reactivation of in rush limiting capability. (Full-load 25°C Cold-start)

1.4 Input Current: 1.2 A max. at any line voltage specified in 2.1 at output full load condition.

2.0 OUTPUT REQUIREMENTS

2.1 Output Power (Rated Power)

The unit total output power from all voltage under steady state condition will not exceed 34 watts

2.2 Output Regulation

Label Information per Safety Agencies according to UL1950 and or EN60950 Requirements

2.2.1 Input Rated Voltage Range: 100~240 VAC.

2.2.2 Line Rated Frequency: 50 HZ to 60 HZ.

2.2.3 Static Load

TABLE 2.2.3

Output	Voltage	Minimum Load	Maximum Load	Surge Current
1	+5V	0A	2A	---
2	+12V	0A	2A	---

2.2.4 Output Voltage

The output voltage shall be statically regulated for all combinations of load (min./ max.), line and environment, including cross regulation (if any) as shown:

TABLE 2.2.4

Output	Voltage	Range	Tolerance
1	+5V	+4.75V~+5.25V	-5%,+5%
2	+12V	+10.8V~+13.2V	-10%,+10%

NOTE: Test measurement will be made at the output connector on the power Supply output cord and well connected on the mating connector.

2.2.5 Ripple and Noise

Differential ripple and noise at the power supply output shall be as shown below when measured under constant load range of 34 watts with an oscilloscope at bandwidth of 20MHz.

TABLE 2.2.5

Output	Voltage	Maximum peak to peak ripple and noise
1	+5V	50 mV
2	+12V	120 mV

NOTE: Test measurement will be made at the output connector on the power Supply output cord. With used an aluminum Electrolytic capacitor of 10uf and ceramic of 0.1uf parallel on output terminal can prevent unknown noise pick up.

2.3 Transient Response and Deviation

The load regulation for +5V is less than +/-5% , for other outputs is less than +/-10% while the measuring is down by changing the measured output loading from+20% to +100% of rated load and keep other is at +60% rated load .The load regulation for +12V is less than +/-10% , for other outputs is less than +/-5% while the measuring is down by changing the measured output loading from+20% to +100% of rated load and keep other is at +60% rated load .

2.4 Turn on, Hold up Time

During turn on and turn off, no voltage shall exceed its nominal voltage by more than 10% and no output will change its polarity with respect to its return line. All outputs shall reach their steady state values within 2 seconds of turn on and the hold up time for the output must be at least 10 mS tested at 110VAC/60HZ input with 80% maximum load on output.

2.5 Efficiency

The efficiency (watt out/watt in) shall be a minimum of 74 % under line input 115Vac/60Hz and full load.

3.0 PROTECTION

3.1 Input Current

An input fuse with a rating of 2A/250V Amps, shall be provided to protect the power supply and the input wiring.

3.2 Over Voltage Protection (OVP)

The power supply shall shut down all outputs when any output voltage reaches to it's over voltage protection trigger point.

Note: This is not a repeatable test, when it triggers it is a perennial shut down.

3.3 Over Current Protection (OCP)

Overload conditions shall cause both the output current and the output voltages to decrease. Removal of an output overload conditions shall permit automatic recovery of the output voltage. The over current protection point Maximum=300% for all outputs.

Note: The total output power should not over Rated power to operate, otherwise will caused the power supply to damage.

3.4 Short Circuit Protection (SCP)

The power supply shall be protected from damage of accidentally short on the output terminal.

4.0 MECHANICAL

4.1 Introduction

The power supply will provide

Output power connector show as in

Table 4.1

FRONT VIEW OF OUTPUT CONNECTOR

Table 4.1 Pin out for DC Connector

PIN	Output Voltage
P1	+12V
P2	+5V
P3	RTN
P4	+5V
P5	RTN

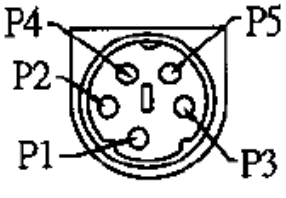

4.2 General Requirements

The power supply must not exceed an audible noise level of 32 dB while operating under any combination of specified load and input voltages and frequencies. This noise level shall be measured according to IEC standards 651 type 1, with the sound level meter pointed directly at the power supply in a free-field condition, at a distance of 1 meter and by selecting nominal "A" weighting frequency attenuation.

4.3 Power Supply Dimensions

The dimensions of the power supply are shown: (110x 50x 30m/m)

4.4 Input / Output Connection

AC PLUG	IEC 320 - C8
DC OUTPUT	2464 20# MINI 5PIN 大 Core 4FT BLACK

4.5 Unit Color: BLACK

5.0 RELIABILITY AND QUALITY CONTROL

5.1 Reliability

The design and construction of this power supply shall exhibit a minimum mean time

between failure of 50,000 hours full rated load operation at 25.0°C, According to the MIL-HDBK-217F.

5.2 Burn-in

The power supply will be performed 100% burn-in at 40°C(±5°C) under 80%-100% of full load on all power supplies.

6.0 ENVIRONMENTAL CONDITIONS

6.1 Storage

The power supply shall be capable of withstanding the following environmental conditions for extended periods of time, without sustaining electrical and/or mechanical damage and subsequent operational deficiencies:

6.1.1 Ambient temperature: -25°C ~ +85°C

6.1.2 Relative Humidity: 10% ~ 95%

6.2 Operation

The power supply shall be capable of operating continuously in any mode without performance deterioration in the following environmental conditions:

6.2.1 Ambient Temperature: 0°C ~ 40°C

6.2.2 Relative Humidity: 10% ~95%.

7.0 EMI EMISSIONS

The power supply meets the radiated and conducted emission requirements for a FCC part 15B class B (DoC) and CISPR22(EN55022) class B

8.0 SAFETY

The power supply must be certified or meet of the following safety standards:

	Certified	Meet
UL /CUL	★	
TUV-GS	★	
PSE	★	
C-TICK	★	
DOIR	★	
EK	★	
BSMI	★	
3C	★	
CE	★	

8.1 Dielectric Strength (Hi-Pot) Test System:

Withstand AC 3 K V/10mA, for 2 sec./ min., primary to secondary.

8.2 Insulation Resistance:

Primary to secondary: 10 M OHM at 500 VDC .

8.3 Leakage current: \leq 0.25mA

9.0 ENVIRONMENTAL PROTECTION

9.1 RoHS and WEEE

This product from design to production all the parts and process should meet the requirement of Restriction of the use of certain hazardous substances in electrical and electronic equipment RoHS directive 2002/95/EC and also meet the directive 2002/96/EC of Waste electrical and electronic equipment (WEEE) .

10.0 PACKAGING: 小白盒(175*85*55mm)

11.0 OUTLOOKING

